



The ACronaut

Volume 6 - Number 4

Prez' Post

Darren Pleasance



It's Spring - Finally! I hope that means more sun and less rain for a change. If any of you are like me, you've had a number of perfectly good weekends spoiled by wind and rain. Let's hope we're beyond that now!

So what's going on? Well, quite a few things...

First off, I'm writing this from my hotel room in St. Louis at my first ever IAC Board meeting. It's great to put names to the faces I've only seen in magazines

or heard cursed on the acro exploder. Strangely, these people all seem to be like pretty nice folks. Go figure... I now join Graham, Allyson, Vicky, and Norm as esteemed Chapter 38 members who serve on our National Board. Interesting that Chapter 38 seems to have the highest percentage of chapter members on the Board. As such, there's no excuse for us not to have an IAC that we're super happy with.



Membership Dues DON'T FORGET!

As of this writing 50 out of 86 2004 paying members have renewed their membership for 2005. Please use the form on the last page or the online Paypal system at www.iac38.org to renew your membership. \$25/year and \$30/year for a family membership.

On other topics, a few important updates regarding goings on in the Chapter:

1) Allyson Parker-Lauck's fundraising event is coming up in a couple of weeks on April 16th at the Nut Tree airport. We should all do what we can to attend and contribute in any way possible. The Chapter has agreed to contribute some funds to help Allyson in her quest to raise enough money to make the trip to Spain this summer as a member of the U.S. National Team, and the event on the 16th is an important opportunity for us to help Allyson host this fun event. There will be a number of us flying up there as a group, so let me know if you're interested in tagging along, as well as letting me know if you have an extra seat in case a Chapter member without an airplane wants to hitch a ride up there.

2) New Jerusalem airport is currently CLOSED!.

(Continued on page 4)

IAC38 Welcomes

Dave Williams - Moss Beach
Josh Horwich - Sunnyvale
Karen & Bear Smith - Grass Valley

In This Issue

President's Post.....	1
Editor's Column	2
Pilots On The Waivers.....	2
Flying High.....	2
Heard It On The Ramp	3
Lycoming Fuel Pump AD.....	4
TCY Box Update	5
Internet Movie Links	5
Internet Resources	5
In-Flight Spade Break.....	6
Allyson Fund-Raiser.....	7
Paso Contest	8
2005 IAC38 Intermediate Free	9
LA Gold Cup	10
Borrego Minifest.....	10
Calendar Of Events.....	11
Partnership For Sale	11

◆ CHAPTER OFFICERS

Darren Pleasance, President
 650.212.1806 H
 415.318.5145 W
president@iac38.org

Ben Freelove, Vice-President
vicepres@iac38.org

Anil Kumar, Secretary
secretary@iac38.org

Howard Kirker, Treasurer
 510.651.6514 H
treasurer@iac38.org

◆ DIRECTORS

Cecilia Aragon
 510.527.4466 H
aragon@dcai.com

Marilyn Dash
marilyndash@comcast.net

Andrew Connolly
CONNOLA2@airproducts.com

Gordon Sorensen
 916.548.2079 H
 916.645.6242 W
twotterdriver@hotmail.com

Angie Niles
Bricket@comcast.net

Peter Jensen
pittss2b@hotmail.com

◆ DIRECTORS EMERITUS

Dr. Richard Rihn
 510.938.4236 H
rihnairco@aol.com

Jeanette Goodman
 209.478.5462

Tom Myers
 650.328.2141 H
 650.473.0200 x108 W
tom.myers@stanfordalumni.org

◆ WEBMASTER

Cris Flint
cris@derbyn.com

◆ YOUNG EAGLES

Terry Ridgway
youngeagles@iac38.org

◆ NEWSLETTER EDITOR

Peter Jensen
editor@iac38.org

Editor's Column

Peter Jensen



This month you can read about: the SWAN safety seminar, a TCY box update, how Che lost a spade, info for LA Gold Cup, Borrego Minifest, and our own Paso contest. Gordon found an aerobatic pinball machine (a must have for any hangar). There's a new Lycoming fuel pump AD out, which will apply to many newer aerobatic airplanes. Angie has

been busy surfing the web for movie clips.

All in all a good collection of aerobatic related stories and information.

We thought others (beside the chapter members) would like to read our newsletter, so starting this month we'll be sending the announcement to chapter presidents and editors across the US.

Enjoy the newsletter.

Peter

Pilots Currently On The Waivers

As of 5/1/2004 our TCY waiver has expired. No one are allowed to fly in the TCY box until the waiver gets renewed. Please observe this temporary restriction. The New J waiver has been renewed. Please contact one of the designated briefers, if you wish to fly in the box (below 1,500 feet).

Pilots on the TCY Waiver (4/1/2005)

NO ONE. Waiver is expired. Awaiting renewal.

Pilots on the New J Waiver (4/1/2005)

Greg Pettit
Peter Jensen
Peter Gillcrist

Ben Freelove
Allyson Parker-Lauck
Howard Kirker

Marilyn Dash
Stephane Nguyen
Darren Pleasance
Jacquie Warda
Mike Davis
Angie Niles
Brett Goldsmith
Todd Whitmer

Cecilia Aragon
Anil Kumar
Rich Perkins
Doug Burr
Alex Drobshoff
Che Barnes
Sean Worthington
Dave Watson

Designated Briefers

Cecilia Aragon
Marilyn Dash
Darren Pleasance

Ben Freelove
Peter Jensen

Flying High

Darrin Silver - www.FlyingHighComics.com

Bad Idea:

Homebuilt Arresting Gear



Darrin Silver

Heard It On The Ramp

Marilyn Dash

The month of March started out with a great weather weekend! It was so great that a group of us flew out to Marysville for the Aerobatic Safety Seminar. Darren, Peter and I flew formation up there and we picked up a few strays on the way back and made it a five ship with Brian Motta and Dennis Yugo. That was so much fun!

The Safety Seminar was terrific! Bill Stein gave a talk on Formation Flying - and Aerobatics in Formation that was very good. Unfortunately, Darren and Brian weren't paying attention well enough and broke nearly every cardinal rule on the way home. ;-) Bill's experiences



with the Red Baron Stearman Squadron were very interesting! He had video and pictures of what a loop, barrel roll, etc. looks like on the wing, in the slot, etc. His speech was worth double the price of admission!

Jon Nash gave a talk on preparing for your sequence. He interviewed some of the best performers around and the all said the same things. The same things you hear about at contests... 1. Stay Hydrated, 2. Plan your flight and fly your plan, 3. Get some solo time before your flight. Jon has a very good speaking style and his experiences lend so much credence to his topic.

The best part of the day had to be the Airshow portion. Wayne did his Inverted Flat Spins demonstration. Bill Cornick was there and did his usual amazing airshow routine. Jon Nash flew his new routine and was terrific! Bill Stein also flew and was AMAZING! I remember when I first met Bill. He just bought his S2B and was flying Sportsman. Boy, he's come a LONG way since then!

I really don't understand why more people don't head up to the Aerobatic Safety Seminar each year! This event is just a terrific way to launch the contest/airshow season. It's also a valuable experience for anyone new to aerobatics. Hopefully, next year we will have more people in attendance AND the same good weather we had this year!

The experience of flying with Darren, Peter, Brian and Dennis reminded me about how much fun we are going to have this year! The next Chapter Fly-Out should be to Allyson's Hangar Party and Fundraiser up at the Nut Tree. Circle April 16th on your calendar and hope for great weather! This should be a ton of fun - and I'll fly wing on you guys anytime! Allyson has lined up some terrific raffles - many items we'd all like to win - so, let's head up there and support our Chapter member and have some fun along the way!

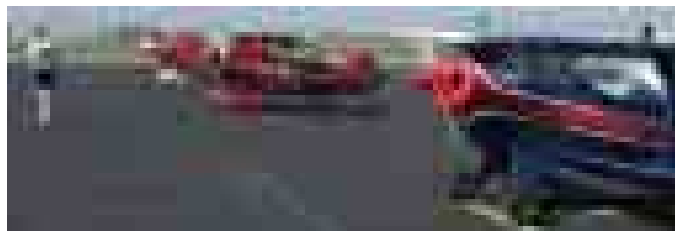

The Borrego Mini Fest is the same weekend as Allyson's party. But, I'll be at the Nut Tree instead. The following weekend, on April 24th, is the Half Moon Bay Dream Machines! They almost always have great weather for that! I suggest we gather again and fly out for that event also.

The next contest will be Apple Valley on May 13th and 14th. That same weekend, the B17 will be at Hayward Airport giving rides. It will be parked outside of Bud Field Aviation and will be there all weekend. Details to follow.

And of course, our own Paso Robles Contest will be the first weekend in June. Make your reservations (move up!) and let's have some fun!

One more thing, we have a new baby in the group. Caitlin Alexis Stout was born Feb. 10 and her parents Justin and Jennifer Stout are thrilled! Of course, Grandpa Brian and Grandma Judy are just as thrilled I'm sure! I certainly hope that Caitlin will be at Paso so we can check her out in person!

See you soon!

Marilyn Dash
Chixfly2

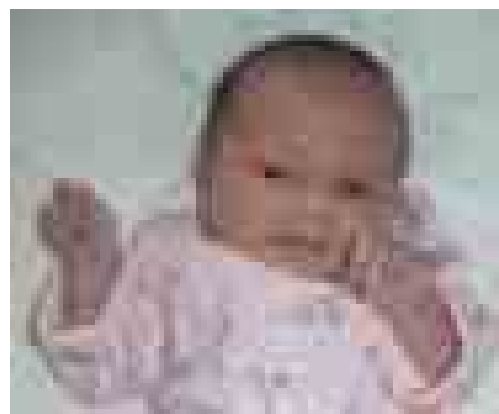

(Continued from page 1) - Prez' Post

I spoke with Rod Buchannon earlier this week and apparently the City of Tracy is attempting to make much-needed improvements to the runway. That's the good news. The bad news is that they're waiting for approval for an FAA grant to get this done and Rod was uncertain whether this was a few weeks, or few months, away. He promised to keep us closely in the loop, but until then, we can still use the box but can't land there.

3) Speaking of "box". Angie Niles and Don Gutridge have been doing a stellar job at pursuing the reapproval of our box at Tracy. The short version of the story as it stands right now is that the City of Tracy is still very supportive and is working behind the scenes at the Oakland FSDO to help us get the box back. Angie and Don have redrawn the dimensions of the Box to address all of the FAA's concerns. Unfortunately, the key FAA person we're having to deal with is being extremely difficult and continues to reference one reason after the next as to why he won't reapprove the box, ranging from accusations that we're flying with less than minimum legal fuel reserves, that we're flying over people in the gravel pits, that we're creating too much noise, and then most recently, that housing is encroaching on our box. Bottom line is that we've now addressed all the concerns and it looks like the key step is going to be a requirement that we hold some community outreach events to enable a public forum to debate the box. The Tracy Airport Commission appears to be willing (almost enthusiastic) to take this on and help us get this community support so we'll see how that goes. Angie, Don, and I have a meeting with the Tracy Airport Commission on April 14th to share with them our plan and get their guidance on the best way to move through this. Let's keep our fingers crossed...

4) Lastly, we're planning to have a session on "Maintaining your Aerobic Airplane" at the next Chapter meeting (April 10) so whether you rent or own, you should plan to attend and learn how to watch for things that break, and how to maintain parts of an aerobatic airplane yourself.

I'll send out an email as we get closer to the Chapter meeting, and Allyson's Nut Tree party so we can get as many of you to participate as we can.

In the mean time, blow out the cobwebs and start flying...

Blue skies,

Darren

Lycoming Fuel Pump AD

Peter Jensen

There's a new AD calling for replacement of the fuel pump on a bunch of Lycoming engines (320, 360, 540) shipped from Lycoming between October 1, 2001 and February 2, 2004 or engines with fuel pumps replaced in the field with a Lycoming fuel pump after October 1, 2001.

The details can be found on:

<http://www.lycoming.textron.com/main.jsp?bodyPage=/support/publications/maintenancePublications/serviceBulletins.html>

Click on SB 565.

Aerobatics Pinball Machine

Gordon Sorensen

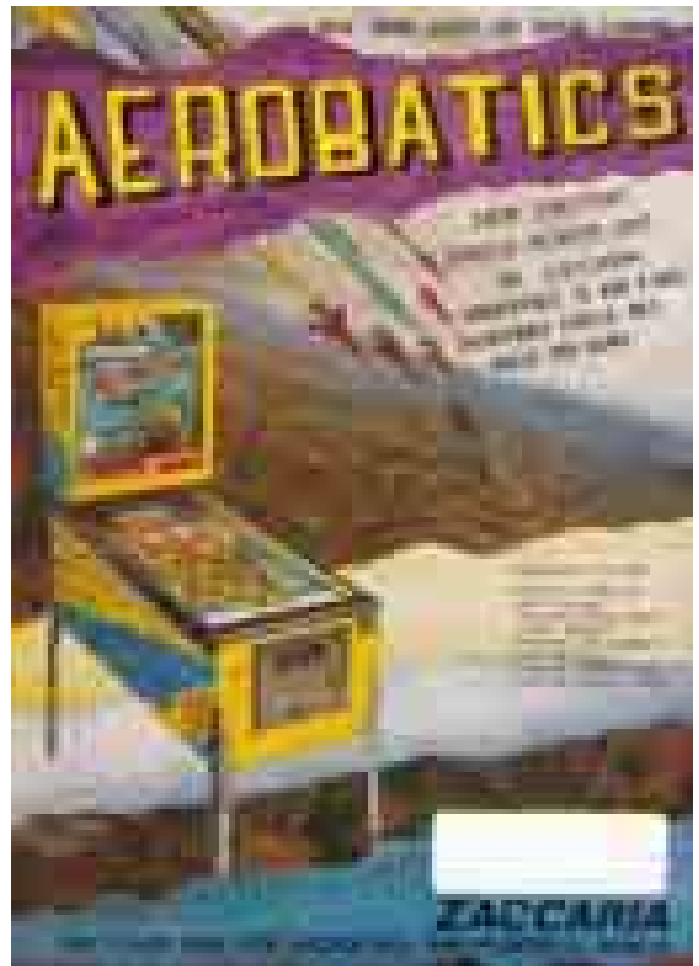

Tracy Box Update

Angie Niles

I am continuing to work with the OAK FSDO to try and re-establish some form of the Tracy Box. During this process OAK FSDO has conveyed to me the perception that they feel there is widespread disregard for observing the Minimum Allowable Fuel requirement (30 min fuel reserve) within the aerobatic community. Darren and I have both denied that our chapter condones such a practice and that we know of no one who flies that way. When asked, they were unable to produce documentation for even a single instance but it is, nonetheless, their perception and it apparently had influenced their TCY box renewal decision. I am working with them to dispel that myth; however, that takes time. Part of my effort was to agree to educate the membership via a series of notifications and discussions that FAR 91.151 is NOT WAIVED and box users must adhere to it.

I know of no occasion of people flying with less than the fuel minimums; however, it is absolutely critical that our members comply with FAR 91.151 and plan their flight such that they land with sufficient fuel on board. The OAK FSDO has nothing to base their claim on and it is extremely important to keep it that way. Failure to comply could be used as grounds for waiver revocation. I don't know idea if they are planning to ramp check and I doubt they would divulge that if they were, but you might keep that in the back of your mind.

On another front, we have strong support from the City of Tracy and the Tracy Airport Commission – although that support has been informal and unofficial in the past. We are on the agenda for the next TAC meeting at which time the commission will make a decision as to whether or not to formally support our aerobatic activities based out of the TCY. The result of that decision will be the basis of a recommendation that will be forwarded on to the City of Tracy proper. Formal support of the TAC and the City of Tracy would include their participation in the OAK FSDO TCY box discussions, an outreach effort to the community around the airport to accept aerobatic activity as one of the ongoing operations and, hopefully, reduce noise complaints, as well as assist us in tracking, mitigating and resolving noise issues.

Below is FAR 91.151 obtained from the FAA website.

§ 91.151 Fuel requirements for flight in VFR conditions.

(a) No person may begin a flight in an airplane under VFR conditions unless (considering wind and forecast weather conditions) there is enough fuel to fly to the first point of intended landing and, assuming normal cruising speed—

- (1) During the day, to fly after that for at least 30 minutes; or
- (2) At night, to fly after that for at least 45 minutes.

(b) No person may begin a flight in a rotorcraft under VFR

conditions unless (considering wind and forecast weather conditions) there is enough fuel to fly to the first point of intended landing and, assuming normal cruising speed, to fly after that for at least 20 minutes.

-Angie

Internet Movie Links

Angie found these gems on the internet. They work best with a broadband connection.

Freeway Landing

This is what might happen when an airliner makes an emergency landing on a freeway:

<http://www.405themovie.com/>

High Energy Airplane Racing

On a racetrack, with airplanes. Hold on to your hat and other loose items:

http://www.airplanecards.com/albums/raph/haute_voltige.wmv

-Angie

Internet Resources

Peter Jensen

The Exploder

This is a well established aerobatics community forum. In order to post and receive e-mails you need to subscribe. However, it has a searchable archive accessible via the web-browser that doesn't require sign-up. I find that extremely useful for both mechanical and flying related stuff. The URL is:

<http://acro.aerobatics.ws/>

Click the 'Communications' link, and then click 'archived'. Really good stuff! The site is maintained by Dr. Gunther Eichhorn.

Aerobatics Discussion Forum

This one is fairly new. It started this year, I think. It currently has about 50 subscribers. Really neat interface. The URL is:

<http://azhighg.galleyhag.com/AeroForum/>

In-Flight Spade Break

Che Barnes



By this time I finally clued myself in on a spade problem. I shot a straight in approach to Tracy from 5,000 feet and landed with no problems.

When I got out of the plane I found that the weld on the leading edge of the spade arm had broke. It looked like someone had taken off the front two bolts of the spade and bent the spade back 180 degrees around the rear two bolts. In this case, the front two bolts were dutifully hanging on to the piece of the spade arm forward of the weld. When the weld broke, the spade caught the wind stream and bent back 180 degrees parallel with the wind, causing the stick to snap to the left and back in an instant. No big deal and no uncontrolled rolls in this case.

Further inspection of the break revealed a thin shiny line of newly exposed aluminum lengthwise along the break. The rest of the thickness of the metal showed a corroded brown color indicating that a crack along the edge of the weld had existed for awhile. A set of new spades and new arms put us back into business and we didn't miss one New J session!

Fly safe!

-Che

If anyone is wondering what happens when the leading edge weld of a spade arm gives way then read on.

This mishap occurred while I was in a dive at the beginning of a practice sequence. I was at about 5,000 feet or so passing through 170 mph or so in a Pitts S2A. I started three wing rocks to the left and on the beginning of the third one the stick snapped out of my hand to a full left deflection then back in an instant. My first thought was that I had hit some type of wake turbulence, perhaps had a bird strike, and that this was going to make for a great IAC Chapter 38 newsletter article.

As I pulled out of the dive the aircraft was holding trim perfectly and showed no abnormal behavior. I noticed something wrong, however, when I rolled. There was an unusually high amount of resistance when the stick was deflected left and not as much resistance with right aileron input. Strange. My next thought was that something was catching the flight controls, such as a loose seatbelt from the front cockpit.

By this time I was climbing even higher and headed towards Tracy airport with the idea in the back of my mind that flight control malfunctions equate to bailing out. The newsletter article seemed to be getting better by the minute. I then did a level speed change to check for controllability in the landing configuration. The resistance in the ailerons changed with speed but the aircraft did not do anything funny when slow.





Last fall, Nut Tree Airport pilot Allyson Parker-Lauck earned one of the coveted positions on the United States Aerobic Team. The Team will be competing at the World Aerobic Championships June 22 - July 2, 2005 in Burgos, Spain.

Allyson and the U.S. Aerobic Team need your help. In years past the U.S. Air Force provided transportation for Team pilots and their airplanes on the C-5A. But due to current world events, the C-5A is not available to the Team this year. Competing at the World Championships will cost each pilot \$20,000 to \$30,000 each.

On Saturday, April 16,
From 1:00 - 4:00 PM,
a benefit is being held to help Allyson raise the money she needs to help Team U.S.A. bring home the gold at the World Aerobic Championships. Come join us for some food, prizes, camaraderie, and fun at Duncan Miller's hangar at the Nut Tree Airport in Vacaville, CA.



The U.S. Aerobic Team (Front Row): Debby Rihn-Harvey, Chandy Clanton, Allyson Parker-Lauck, Janet Fitzke, and Vicki Cruse. (Back Row): Robert Armstrong, Hubie Tolson, Kirby Chambliss, Michael Racy, and David Martin. Not Pictured: Zach Heffley.



If you can't attend...

donations are still needed. You can make your tax deductible donation by sending a check made payable to the International Aerobic Club and writing Allyson's name on the memo line. Checks should be sent to:

Lisa Popp, IAC Executive Director
P.O. Box 3086
Oshkosh, WI 54903

Or donate online by visiting the U.S. Aerobic Team Website at www.usaerobicteam.com

For more information, contact Allyson Parker-Lauck by phone at 707-580-1791 or by email at allyson@usaerobicteam.com

Northern California Regional Aerobatic Contest

June 2 - 5, 2005

Paso Robles, California

Note: This information is preliminary and subject to change

Northern California Aerobatic Challenge sponsored by IAC 38. The competition will be held at Paso Robles Municipal Airport - locator PRB. Primary through Unlimited Power categories will be flown. For more information visit:

<http://www.iac38.org/paso2005.htm>

Schedule

Wednesday:	all day	Setup
Thursday:	7:00am - sundown	Registration & practice
Friday:	7:00am - 7:30am	Pilot briefing
	8:00am - sundown	Contest flying
	7:30pm	Pizza
Saturday:	7:00am - 7:30am	Pilot briefing
	8:00am - sundown	Contest flying
	8:00pm	Banquet & Awards
Sunday:	all day	Reserve and break down

Pre-registration

We request that you take a moment and pre-register for the contest - it will make our lives easier and make your tech go quicker! Our objective for pre-registered contestants is you show up, sign your form, and practice.

To pre-register use this web URL:

<http://www.iac38.org/pasoreg2.htm>

Fees

Primary	\$25
Sportsman	\$50
Intermediate, Advanced, and Unlimited	\$75

Food

Food available on the airport Thursday, Friday, Saturday. Friday evening pizza party. Saturday evening banquet. The banquet will tentatively be held at the Estrella Warbird Museum. It will be good!

Contest Director

Dave Watson
E-mail: pasocd@iac38.org
Phone: (408) 445-1289

Accommodations

We have booked blocks of rooms at the following hotels.

All blocks expire on 5/2/05. You must book in your own room before this date or you will not be able to take advantage of these blocks.

All prices per night plus taxes. Mention "Aerobatic Contest" to get block rates.

Motel 6 - (805) 239-9090

20 rooms - All rooms are 2 Queens
single occupancy - \$39.99
double - \$45.99
triple - \$48.99
quad - \$51.99

Deposits refunded if cancelled by 6/1/05.

Holiday Inn Express - (805) 238-6500

15 rooms
single or double occupancy - \$115
Deposits refunded if cancelled 72 hr prior to arrival.

Black Oak Motel - (805) 238-4740

20 rooms - All rooms in block are NON-Smoking
1 King or 2 Twins - \$90.00 (10% add'l discount if AAA or AARP)
Deposits refunded if cancelled 24 hr prior to arrival.

Hampton Inn (was Paso Robles Inn) - (805) 238-2660

15 Suites in block
Suites with 1 King or 2 Queens - \$122.55
Deposits refunded if cancelled 48 hr prior to arrival.

Adelaide Inn - (805) 238-2770

Note: there is a sorority party scheduled at this hotel.
5 rooms only - all are SMOKING rooms
2 Queens - \$85/ Wed-Thurs, \$101/Fri-Sat
Deposits refunded if cancelled on or before day of arrival.

The following are other local hotels - we do not have blocks and we do not have their rates. Please call for details.

Travel Lodge - (805) 238-0078

Melody Ranch Motel - (805) 238-3911

Relax Inn - (805) 238-3013



2005 IAC38 Intermediate Free

Peter Jensen

At the March Chapter meeting we refined the chapter Intermediate Free. We needed to shave off 1-2 points to make it fit. We did so by replacing the back-to-back 90 and 270 turns with a 180 turn and replacing the 1 1/2 spin with a

single turn one. The sequence in Visio and PDF format can be found on the IAC38 web-site. Look under 'Competition|Sequence Library'.

-Peter

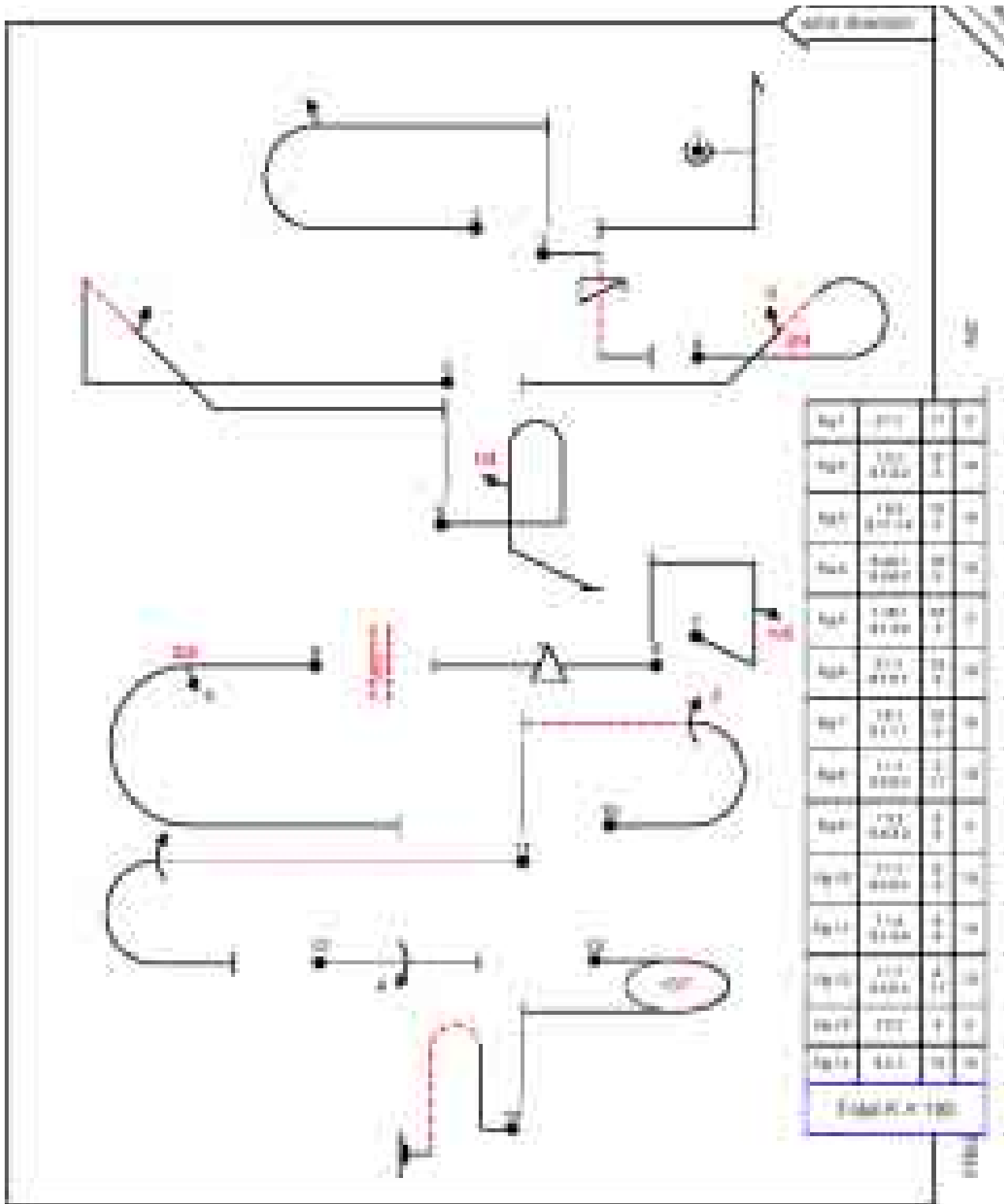

31st Annual Los Angeles Gold Cup

May 12-14, 2005

The Los Angeles Aerobatic Club Proudly Presents the 2004 Gold Cup. The contest will be held at Apple Valley Airport (APV)

vajo Rd, Suite 101, Apple Valley, CA 92380. Rental Car Reservations are recommended to assure the availability of the desired type of vehicle.

Catagories

5 Category IAC Regional Contest

Registration and Practice

Competition Box open for practice on Tues-Wed.
Thursday: Registration & 10 minute practice in box.

Other

Parachute Rigger service. Restaurant on field. Limited hangar space.

Schedule

Thursday 1800 Order of Flight drawing and Pizza Party.
Friday 0700 Briefing, Competition flights all day.
Saturday 0700 Briefing, Competition flights
1900 Banquet

Rental Cars

There is only one rental car agency that will pick up at the airport and that is Enterprise Rent A Car, Phone 760-240-0330, They are about .3 miles from the airport at 13631 Na-

Motels

Best Western Green Tree Inn and Suites	760-245-3461
Comfort Suites Victorville	760-245-6777
Econo Lodge Hesperia	760-949-1515
Holiday Inn Exp Suites Hesperia	877-531-5084
Red Roof Inn Victorville	760-241-1577
Howard Johnson Express Victorville	760-243-7700
Ramada Inn Victorville	760-245-6565
Days Inn Suites Victorville	760-948-0600
Travelodge Victorville	760-241-7200
Super 8 Motel	760-949-3231
Motel 6 Victorville	760-243-0666
Budget Inn	760-243-5757
Budget Inn	760-241-8010

Contest Director

Steve Andelin
Email: acrotest@aol.com
Phone: (949) 646-1270

We are truly looking forward to seeing you at the APPLE VALLEY GOLD CUP 2004.

Borrego Minifest 2005 Regional Aerobatic Contest

April 16, 2005

Sponsored by San Diego Aerobatic Club
IAC Chapter 36.

The contest will be held at Borrego Springs
Airport - Locator L08

Categories

Primary and Sportsman Only

Registration and Practice

Friday, April 15, 9am till sunset

Contest Details

Saturday, April 16, 7am - Pilot Briefing at Crosswinds Café
Breakfast Available at Crosswinds Café (on airport) at 0630
Saturday Awards Ceremony after Contest on Saturday Evening

RAIN DAY (if required): Sunday, April 17



Rental Cars

Desert Car Rental (Airport Manager) (760) 767-7415

Motels

La Casa Del Zorro Resort	(800) 824-1884	(760) 767-5323
Borrego Springs Resort	(888) 826-7734	(760) 767-5700
Palm Canyon Resort	(800) 242-0044	(760) 767-5341
The Palms at Indian Head		(760) 767-7788
Hacienda Del Sol		(760) 767-5442
Oasis Motel		(760) 767-5409
Stanlunds		(760) 767-5501

Airport Manager

Vicki Cole (760) 767-7415 -- CTAF/UNICOM: 122.80

Contest Director

Contest Director: Bruce Laurie
e-mail: brucelaurie@cox.net
Phone: (760) 789-8588

Calendar of Events

April	10	Chapter Meeting - 4pm <i>Aircraft Maintenance</i>
	16	Allyson Fundraiser - 1pm <i>allyson@usaerobaticsteam.com</i>
	16	Borrego Mini-Akrofest <i>brucelaurie@cox.net</i>
May	8	Chapter Meeting - 4pm <i>Chapter Fly-out/skydiving</i>
	13-14	LA Gold Cup - Apple Valley, CA <i>acrotest@aol.com</i>
June	3-4	Northern California Aerobatic Championship, Paso Robles, CA <i>daw@micruscorp.com</i>
	17-18	Apple Cup - Ephrata, WA <i>john.coffey@cingular.com</i>
July	10	Post Paso Party
August	14	Chapter Meeting - 4pm <i>WAC Review - Allyson</i>
	26-27	Beaver State, Pendleton, OR <i>grhoward@hotmail.com</i>
September	3-5	Delano Contest, CA
	11	Chapter Meeting - 4pm <i>Advanced Spin Recovery</i>
	14-18	Reno Air Races, NV
	25-30	2005 Nationals, Grayson Co., TX <i>CWHurley@aol.com</i>
October	9	Chapter Meeting - 4pm
	14-15	Borrego Akrofest, San Diego, CA <i>N77TW@aol.com</i>
November	3-6	Tequila Cup Contest, Tucson, CA <i>mic@MicroImportService.com</i>
	13	Chapter Meeting - 4pm
December	2-4	AZ State Championship Contest <i>(proposed dates)</i>
	??	X-Mas Party

FOR SALE

Share in Unlimited Aerobatic Monoplane



Looking for partner(s) in the Sabre, a high-performance monoplane designed by Dan Rihn, built by Alan Geringer, and modified by Zivko Aeronautics with advice from Leo Loudenslager. Has Edge wing and Lycoming AEIO-540 built by Dick DeMars and top-overhauled by Lycon. Airplane has won medals at World and National Aerobatic Championships.

Prefer to base it at Tracy or Livermore, but will consider anywhere in the Bay Area.

- Built in 1990 by Remle Aviation (Alan Geringer)
- 960 TT, 219 STO/H
- Annual done 3/05
- MT 3-bladed composite prop, MTV-9-B-C/C200
- King radio & transponder
- Impeccably maintained
- Always hangared
- NDH

Will sell either 1/2 share or two 1/3 shares:
\$50,000 for 1/2 share, \$33,333 for each 1/3 share

Cecilia Aragon
aragon@dcai.com
510-527-4466
<http://dcai.com/sabre>

IAC Chapter 38 Membership Application/Renewal Form

Name: _____ Spouse: _____
 Address: _____

 City: _____ State: _____ Zip: _____
 Home Phone: _____ Work Phone: _____
 E-mail 1: _____ E-mail 2: _____
 IAC #: _____ EAA #: _____
 Certificate #: _____ EAA Expiration Date: _____
 Judge: Regional National
 Competition: None Basic Sportsman Intermediate Advanced Unlimited
 Aircraft: _____ N #: _____
 Referred By: _____
 Dues: Single Membership (\$25/year) Family Membership (\$30/year)

Send with check, made payable to "International Aerobatic Club Chapter 38", to:
Howard Kirker, IAC38 Treasurer - 2279 Ocaso Camino - Fremont, CA 94539



Peter Jensen
Editor, IAC 38
310 Ellmar Oaks Loop
San Jose, CA 95136



Chapter Meeting:

Sunday April 10th, 2005, 4pm

Attitude Aviation

Livermore Airport

Aircraft Maintenance - Doing your own annual